

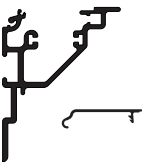







PRODUCT UPDATE: 2" Soft Signage Snap Tensioning System

Ideal for all dye-sublimation and direct printed fabrics

Part	Part Number	Length	Finish
 2" Soft Signage Snap Tension Frame	3091	20'-0"	Mill
 2" Soft Signage Snap Tension Frame Cover	3094	20'-0"	Mill
 Soft Signage Grip Strip II	3097	12'-2"	Black
 Soft Signage Tension Frame Z-Clip	3099	12'-0"	Mill
 2 Piece Corner Key	5890		
 Corner Angle (2" x 2" x 3/16")	5303	3/16"	
 Soft Signage Snap Cover Spring	5893		
Bundled- Frame, Cover, and Grip Strip	B3091 B3091A	10'-0" 10'-0"	Mill Clear Anodized

Features & Benefits

- Fast, easy frame assembly.
- Designed for illuminated and non-illuminated applications.
- No sewing or silicone beads required.
- Snap Cover is available in Mill finish and Clear Anodized.
- Light weight frame - single and double face.
- Full bleed face.
- Fabric does not need to be cut to exact size.

Pre-Cut Kits Available

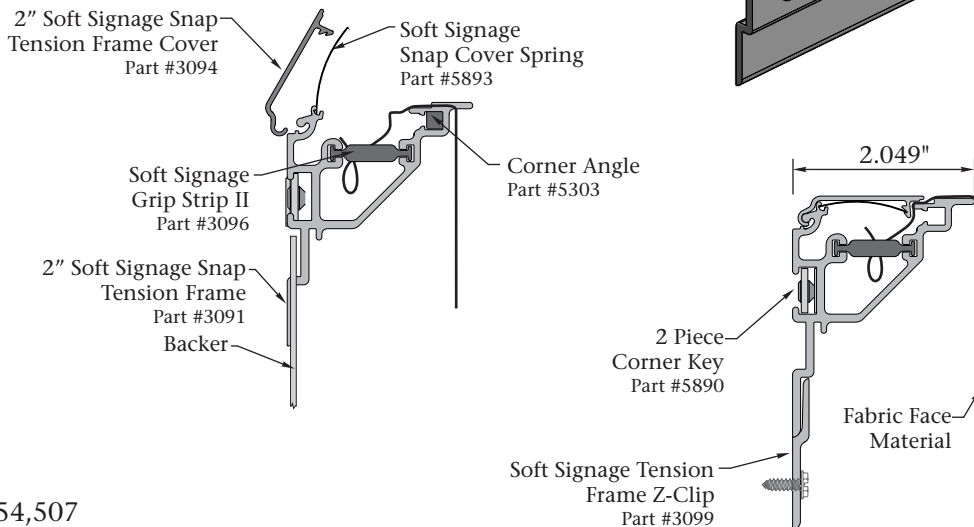
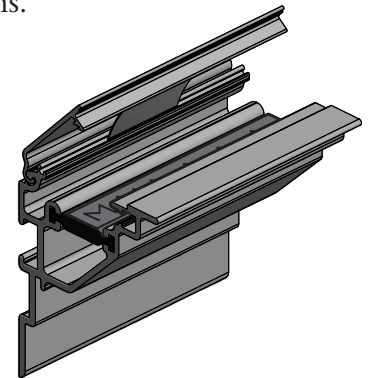

US Patent Number 8,595,966
Canadian Patent Number 2,754,507